

# Zubehör - Zylinder

## Gabelköpfe mit Bolzen

Optional: Werkstoff 1.4571 -ES 4A

Typ	Typ	A	B	C	D	E	F	G	H
GAK 8/10	GAK 8/10 ES	M 4	8	16	11	4	21	8	4
GAK 12/16	GAK 12/16 ES	M 6	12	24	16	6	31	12	6
GAK 20	GAK 20 ES	M 8	16	32	23	8	42	16	8
GAK 25/32	GAK 25/32 ES	M 10 x 1,25	20	40	27	10	52	20	10
GAK M10	GAK M10 ES	M 10	20	40	28	10	52	20	10
GAK 40	GAK 40 ES	M 12 x 1,25	24	48	33	12	62	24	12
GAK M12	GAK M12 ES	M 12	24	48	33	12	62	24	12
GAK 50/63	GAK 50/63 ES	M 16 x 1,5	32	64	43	16	83	32	16
GAK M16	GAK M16 ES	M 16	32	64	43	16	83	32	16
GAK 80/100	GAK 80/100 ES**	M 20 x 1,5	40	80	51	20	105	40	20
GAK 125	GAK 125 ES**	M 27 x 2	55	110	72	30	148	55	30
GAK 160/200	---	M 36 x 2	72	144	84	35	188	70	35
GAK 250	---	M 42 x 2	84	168	104	42	232	85	42
GAK 320	---	M 48 x 2	96	192	117	50	265	96	50

\* Typ Edelstahl kann optisch von der Zeichnung abweichen, \*\* in Anlehnung an DIN/ISO

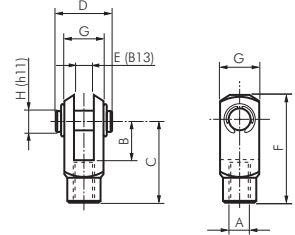

## Gabelköpfe (Außengewinde) mit Bolzen

Typ	A	B	C	D	E	F	G	H	GL
GAKA M6	M 6	12	37	17	6	44	12	6	15
GAKA M8	M 8	16	47	22	8	57	16	8	20
GAKA M10	M 10	20	57	27	10	69	20	10	25
GAKA M12	M 12	24	68	33	12	82	24	12	30

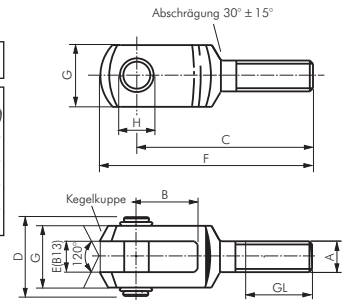

## Gelenkköpfe

Werkstoffe: Typ Stahl verzinkt: Gehäuse: Stahl verzinkt, Lagerung: Messing/PTFE, Innenring: 100Cr6  
Typ Edelstahl: Gehäuse: 1.4301, Lagerung: 1.4301/PTFE, Innenring: 1.4021

Typ	Typ	A	B	C	D	D2	L	H
SGS 8/10	SGS 8/10 ES	M 4	8	6,0	5	18	10	27
SGS 12/16	SGS 12/16 ES	M 6	9	6,75	6	20	12	30
SGS 20	SGS 20 ES	M 8	12	9,0	8	24	16	36
SGS 25/32	SGS 25/32 ES	M 10 x 1,25	14	10,5	10	28	20	43
SGS M10	SGS M10 ES	M 10	14	10,5	10	28	20	43
SGS 40	SGS 40 ES	M 12 x 1,25	16	12,0	12	32	22	50
SGS M12	SGS M12 ES	M 12	16	12,0	12	32	22	50
SGS 50/63	SGS 50/63 ES	M 16 x 1,5	21	15,0	16	42	28	64
SGS M16	SGS M16 ES	M 16	21	15,0	16	42	28	64
SGS 80/100	SGS 80/100 ES	M 20 x 1,5	25	18,0	20	50	33	77
SGS 125	SGS 125 ES	M 27 x 2	37	25,0	30	70	51	110
SGS 160/200	SGS 160/200 ES	M 36 x 2	43*	28,0	35	80	56	125
SGS 250	---	M 42 x 2	49*	33,0	40	91	60	142
SGS 320	---	M 48 x 2	60*	45,0	50	117	65	162

\* Abweichend von Norm

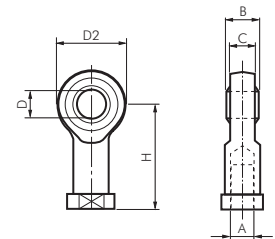

## Gelenkköpfe aus Kunststoff

Werkstoff: Hochleistungspolymer, selbstschmierend  
Temperaturbereich: -40°C bis max. +80°C  
Einsatzbereich: nasse Umgebung, schwache Säuren und Laugen, Wasser, extremer Schmutz

Typ	A	B	C	D	D2	L	H
SGS 12/16 KU	M 6	9	7,0	6	20	12	30
SGS 20 KU	M 8	12	9,0	8	24	16	36
SGS 25/32 KU	M 10 x 1,25	14	10,5	10	30	20	43
SGS 40 KU	M 12 x 1,25	16	12,0	12	34	24	50
SGS 50/63 KU	M 16 x 1,5	21	15,0	16	42	31	64
SGS 80/100 KU	M 20 x 1,5	25	18,0	20	50	33	77

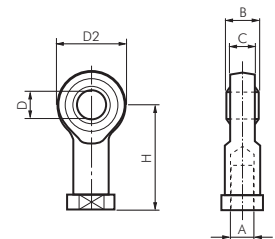

## Gelenkköpfe 90°

Werkstoffe: Körper: Aluminium-Druckguss, Zapfen und Kugel: Stahl verzinkt

Typ	d1	d2	d3	L	l	l1	l2	l2	l2	D1	D2
SGS 12/16-90	M 6	10	20	40,5	36,0	30	11	14	26	10,0	13
SGS 20-90	M 8	12	24	49,0	43,5	36	12	17	31	12,5	16
SGS 25/32-90	M 10 x 1,25	14	30	58,0	51,5	43	15	21	37	15,0	19
SGS 40-90	M 12 x 1,25	19	32	66,0	57,5	50	17	25	42	17,5	22
SGS 50/63-90	M 16 x 1,5	22	44	84,0	79,5	64	23	32	60	22,0	27
SGS 80/100-90	M 20 x 1,5	29	50	99,0	90,0	77	25	35	68	27,5	34

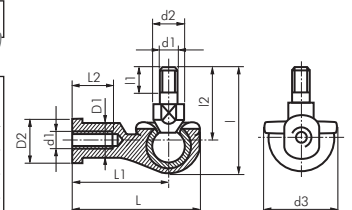

Alle Angaben verstehen sich als unverbindliche Richtwerte! Für nicht schriftlich bestätigte Datenauswahl übernehmen wir keine Haftung. Druckangaben beziehen sich, soweit nicht anders angegeben, auf Flüssigkeiten der Gruppe II bei +20°C.